

Product data sheet

Characteristics

XVR3M03

Harmony XVR, Illuminated beacon without buzzer, green, Ø100, integral LED, 100...230 V AC



Main

Range of product	Harmony XVR
Product or component type	Beacon
Device short name	XVR3
Beacon or indicator bank unit type	LED unit
Mounting diameter	100 mm
Light source	LED, green
Device application	Bulldozer Forklift Automated guided vehicle (AGV)

Complementary

Signalling type	Blinking Rotating Flashing
Assembly style	Ready assembled
Material	PC (polycarbonate): lenses PBT (polybutylene terephthalate) + PC (polycarbonate): body EPDM (ethylene propylene diene monomer): base
[Us] rated supply voltage	100...230 V AC
[Ue] rated operational voltage	90...253 V AC
Inrush current	0.5 A
Power consumption in W	2.9 W
Marking	CE
Installation direction	Upright indoor Sideways indoor Inverted indoor Upright outdoor
Electrical insulation class	Class II
Current consumption	500 mA
Length	100 mm
Width	100 mm
Height	139 mm
Net weight	0.484 kg

The information provided in this documentation contains general descriptions and/or technical characteristics of the products of the performance of the products contained herein. This documentation is not intended as a substitute for and is not to be used for determining suitability or reliability of these products for specific user applications. It is the duty of any such user or integrator to perform the appropriate and complete risk analysis, evaluation and testing of the products with respect to the relevant specific application or use thereof. Neither Schneider Electric Industries SAS nor any of its affiliates or subsidiaries shall be responsible or liable for misuse of the information contained herein.

Environment

Product certifications	CCC
Ambient air temperature for operation	-10...50 °C
Ambient air temperature for storage	-20...70 °C
Relative humidity	35...85 % without condensation
Vibration resistance	4.6 gn (sideways) 4.6 gn (inverted) 4.6 gn (upright)
IP degree of protection	IP65 (upright) IP23 (sideways) IP23 (inverted)

Packing Units

Unit Type of Package 1	PCE
Number of Units in Package 1	1
Package 1 Weight	649.0 g
Package 1 Height	18.1 cm
Package 1 width	13.5 cm
Package 1 Length	13.7 cm
Unit Type of Package 2	S04
Number of Units in Package 2	8
Package 2 Weight	6.194 kg
Package 2 Height	30.0 cm
Package 2 width	40.0 cm
Package 2 Length	60.0 cm

Offer Sustainability

Sustainable offer status	Green Premium product
REACH Regulation	REACH Declaration
EU RoHS Directive	Pro-active compliance (Product out of EU RoHS legal scope) EU RoHS Declaration
Toxic heavy metal free	Yes
Mercury free	Yes
RoHS exemption information	Yes
China RoHS Regulation	China RoHS Declaration
Environmental Disclosure	Product Environmental Profile
Circularity Profile	End Of Life Information

Dimensions

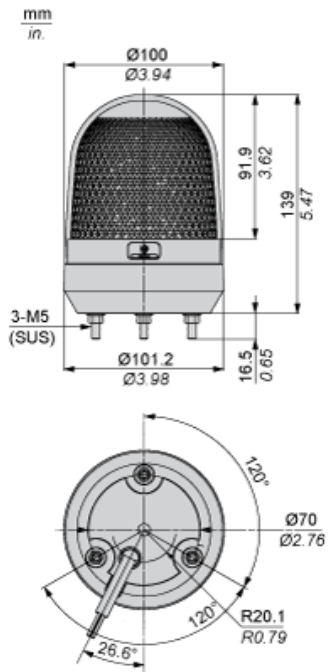

Wiring Diagram

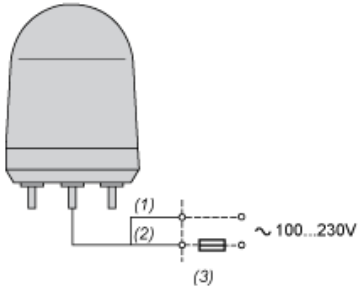

- (1) Black
- (2) White
- (3) Fuse(Rated Current>2A)